



imagination at work

SERIES B3: 15C175 ROOTS® Meter

	UNITS Imperial	UNITS Metric
Temperature Range	deg. F -40 to +140	deg. C -40 to +60
Base Rating (Q Max.)	acfh 1500	m ³ /h 42,5
Max. Operating Pressure (MAOP) ¹	psig 175	kPa 1200
Leak Test (125% MAOP)	psig 219	kPa 1510
Static Test (2 x MAOP)	psig 350	kPa 2400
Rangeability +/- 1%	ratio 40:1	ratio 40:1
Rangeability +/- 2%	ratio 78:1	ratio 78:1
Start Rate	cfh 1.94	m ³ /h 0,0549
Stop Rate	cfh 1.57	m ³ /h 0,0445
Flow Rate @ 0.5" w.c., Gas	cfh 1500	m ³ /h 42,5
Avg. Differential, 100% Flow	in. w.c. 0.75	mbar 1,9
Max. Pressurization Rate	psig/sec 5	kPa/sec 35
Max. Operating Speed	rpm 2500	rpm 2500
Gear Ratio	ratio 1000:1	ratio 352,9411:1
Displaced Volume/Revolution	cf 0.01	m ³ 0,000283
Drive Rate, CD	cf/rev 10	m ³ /rev 0,1
Drive Rate, TD	cf/rev 100	m ³ /rev 1
Temp. Compensating Range (TC,TD)	deg. F -20 to +120	deg. C -29 to +49
Min. Odometer Reading	cf 0.2	m ³ 0,002
Odometer Turnover	yrs. 7.61	yrs. 2,69
Nominal Pipe Size	in. 2	mm 50,8
Flange-to-Flange	in. 6-3/4	mm 172
Flange Connection	ANSI 150#FF	ANSI 150#FF
Bolts per Flange	qty. 4	qty. 4
Bolt Size ²	in. 5/8 - 11	in. 5/8 - 11
Flange Bolt Hole Depth	in. 15/16	mm 23,8
Bolt Torque: Lubricated/Non-Lub.	ft.-lb. 55/60	N-m 74/81
Restricting Orifice (120%)	in. 3/8	mm 9,5
Oil Capacity – Side Inlet	oz. 0.8	ml 24
Oil Capacity – Top Inlet	oz. 3	ml 89
<i>Counter Version (CTR)³</i>		
Net Weight	lbs. 24	kg 10,9
Shipping Weight	lbs. 27	kg 12,2
Carton Size	in. 23 x 11 x 9	cm 58 x 28 x 23
<i>Counter with Instrument Drive (CD)³</i>		
Net Weight	lbs. 27	kg 12,2
Shipping Weight	lbs. 30	kg 13,6
Carton Size	in. 25 x 14 x 13	cm 66 x 35 x 33

NOTES:

¹ Available with 200 PSIG rating.

² Bolt Length varies by application.

³ Weights and dimensions available for CPS,TC,TD,TPS upon request.

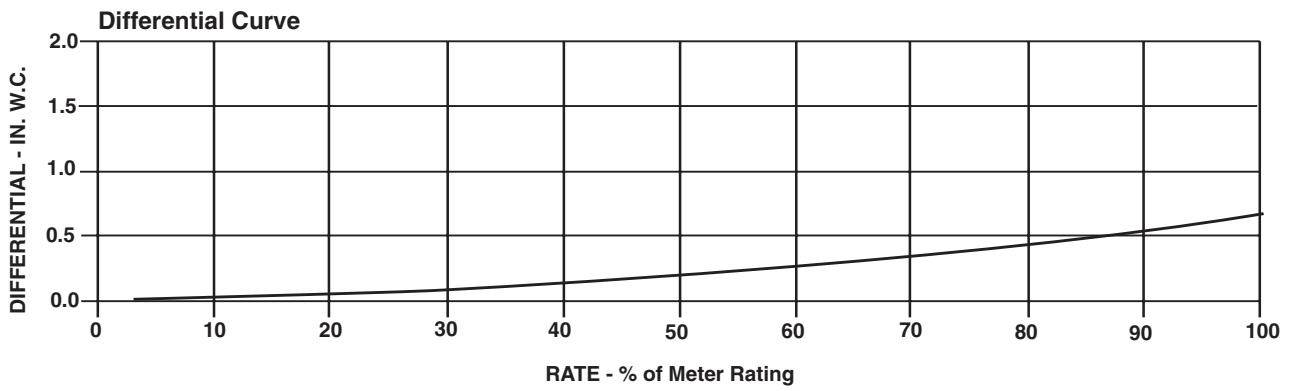
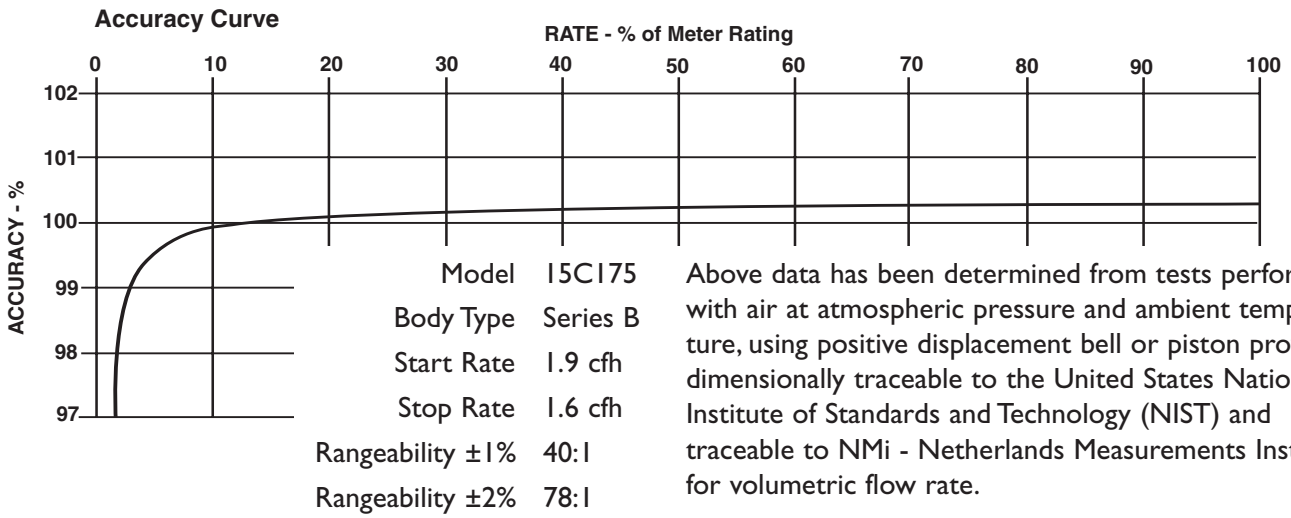

15C175 Series B3	Overall Length		Overall Height		Width (Flange/Flange)		Centerline to Accessory End (CL-AU)		Request Detailed Drawing Number
	inches	mm	inches	mm	inches	mm	inches	mm	
CTR / TC	15-9/32	388	6	153	6-3/4	172	10-3/32	256	D054516-000
CD / TD	19-1/16	485	6-9/32	160	6-3/4	172	13-7/8	353	D054430-000
CPS / TPS	17-7/16	443	6	153	6-3/4	172	12-1/4	311	D054669-000
IMC/C	21-3/16	538	6	153	6-3/4	172	15-25/32	401	D056485-000
IMC/W	20-11/16	525	6	153	6-3/4	172	15-9/32	388	D056701-000

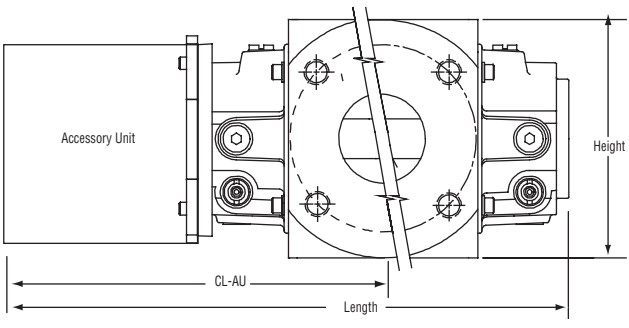

To order

Specify: Meter Series, Size and Type (i.e., GE Meter Series B3 15C175 CD).
 For CD or TD, specify Inlet (Top or Side) and ID Rotation (CW-B or CCW-A).
 For Pulser, specify Single or Dual Connectors and Connector Type (MS Circular, Conduit or Cable Gland).
 For more specific ordering information on the electronic products, request: TS:SSP, TS:IMC/C or S:IMC/W.
 Contact the factory for other available information, options, or special requests.

